



Qzone

Falling in love with quiet

Qzone

Product Data Specification

Add a bit of private space to your open plan office. Qzone is perfect for sensitive phone calls, working on confidential documents, or just a bit of peace and quiet. Available in white or new oak with a large range of colour/ print customizations available on the outer side panels.

Standard Features

In stock in Grey/ White and Grey/ New Oak

Toughened glass door

Flat packed for easy moving and transportation, fits comfortably in most lifts

Motion sensor, light, extraction fan, GPO & USB power outlet

Made with acoustic panel that helps tune out noise

10 years warranty (excludes electrical components)

Comes with bench to take notes or work on your laptop

Internal walls absorb 75% of sound waves (100 fold reduction in sound intensity)

Optional upgrades

Wireless fast charge in worktop

Change outer e-panel colours: 4 weeks lead time

Printing on white outer panel (includes artwork design & approval): 4 weeks lead time

Glass door and/ or rear panel frosting (includes artwork design, work completed by sign maker after assembly)

Window panel to back wall- special order: 12 weeks

Box shelf upgrade (second shelf level and bag hook)- special order: 12 weeks

Colour Options:

E-panel sides:

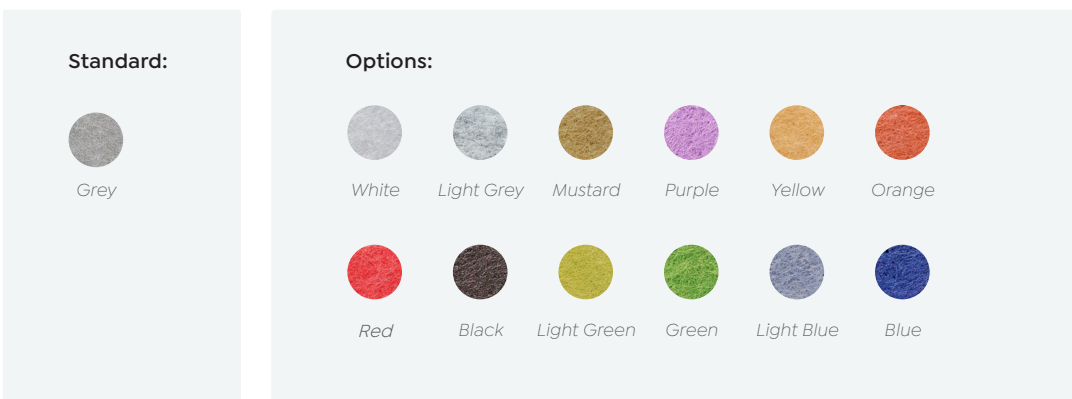

Melamine Front & Back:

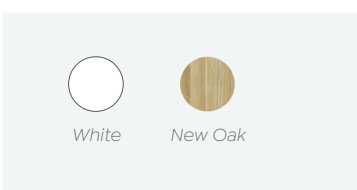

Product Data Specification

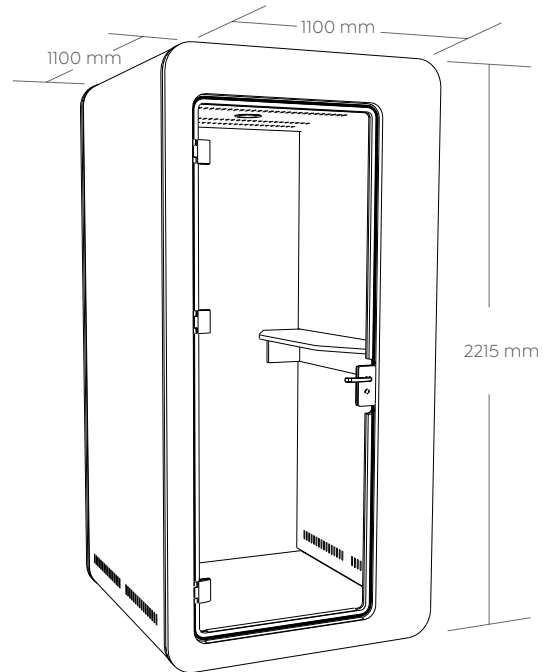
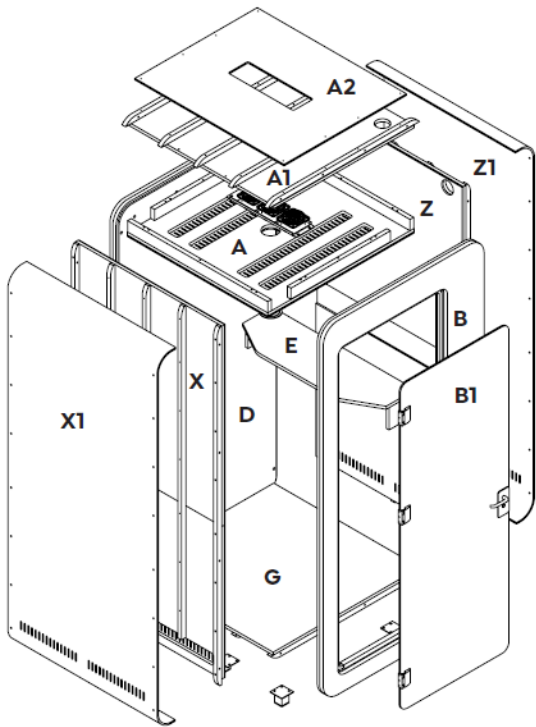

Exploded parts:

- | | |
|------------------------|-------------------------------|
| A Ceiling Panel | X Side Panel |
| A1 Top Panel | X1 E- panel side panel |
| A2 E- panel | Z Side Panel |
| B Front panel | Z1 E- panel side panel |
| B1 Glass Door | |
| D Back panel | |
| E Shelf | |
| G Bottom Panel | |

Specifications:

Weight: 275 kg.
 Size: 1100 (w) x 1100 (d) x 2215 (h) mm.

Packing Type:

10 cartons
 Max weight: 61.5kg
 Min weight: 21.75kg
 Assembly time: 2 people, 2 hours,
 simple electrical work required.



New Oak / Grey



White / Grey

